

H340AJ

HYBRID ARTICULATING BOOM LIFT



Performance

Platform Height	10.28 m
Working Height	12.28m
Horizontal Outreach	6.06 m
Up and Over Height	5.17 m
Swing	355 Degrees Non-Continuous
Platform Capacity	230 kg
Platform Size	0.76 x 1.52 m
Platform Rotator	180 Degrees Hydraulic
Jib	1.22 m
Weight	4,675 kg
Drive Speed	5 km/hr
Gradeability	45%
Turning Radius	
Inside	1.52 m
Outside	3.96 m

Standard Specifications

Power

Diesel Engine	
Kubota Z482	8.3 kW
Fuel Tank Capacity	49.2 L
Batteries	8 x 12V 100 AH

Tyres

Standard	Non-marking Solid Cushion Lug
----------	-------------------------------

Hydraulic System

Tank Capacity	18.92 L
Auxiliary Power	12V DC

Standard Features

- 12.2 m Articulating Jib
- 355 Degree Non-Continuous Swing
- Platform 0.76 x 1.52 m Side Entry Self-closing, Self-locking Gate
- 180 Degree Hydraulic Platform Rotator
- Platform Console Machine Status Light Panel*
- 3 Degree Tilt Alarm/Indicator Light
- Swing-Out Engine Tray
- Gull-Wing Steel Turntable Hoods
- 12V-DC Auxiliary Power
- Hourmeter
- Proportional Controls
- Control ADE® System
- Lifting/Tie Down Lugs
- Horn
- Oscillating Axle
- Cast Aluminum Control Box
- All Motion Alarm
- Flashing Amber Beacon

* Provides indicator lights at platform control console for system distress, low fuel, 3 degree tilt light, and foot switch status.



- **Environmentally Friendly** — A smaller diesel engine with a “direct electric drive system” means less fuel consumption, less noise and less environmental impact.
- **Power and Performance** — Four separate drive motors provide four-wheel drive and terrainability that meets or exceeds the performance of comparable diesel models.
- **More access** — The articulating jib gets you in those hard-to-reach places.
- **Greater Strength** — Steel hoods provide added durability.

Accessories & Options

- 30 x 48 in. (0.76 x 1.22 m) Platform
- Mesh to Mid Rail
- 1/2 in. Air Line to Platform
- SkyGuard®
- Squawker / White Noise Motion Alarm
- AC Receptacle in Platform
- AC Generator
- Chassis Illumination Lights
- Platform Worklights
- Hostile Environment Kit
- Special Hydraulic Oils

H340AJ

HYBRID ARTICULATING BOOM LIFT



Dimensions

All dimensions are approximate.

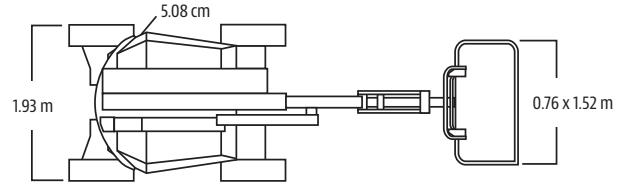
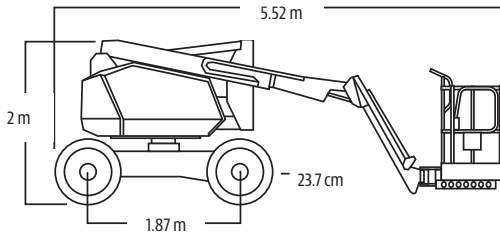

Reach Diagram

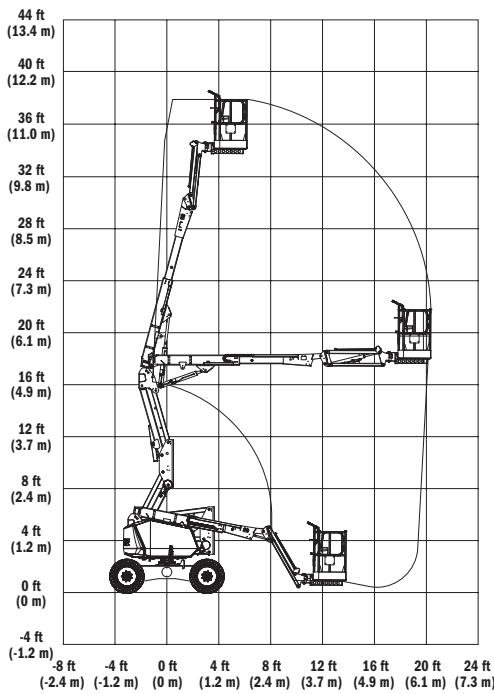

The JLG "1 & 5" Warranty

JLG Industries, Inc. backs its products with its exclusive "1 & 5" Warranty. We provide coverage on all products for one (1) full year and cover all specified major structural components for five (5) years. Due to continuous product improvements, we reserve the right to make specification and/or equipment changes without prior notification. This machine meets or exceeds AS/NZS 1418.10 2011 as originally manufactured for intended applications.



JLG Industries (Australia)

358 Park Road
Regents Park, NSW 2143
Telephone 02 8718 6300
Fax 02 8718 6377

www.jlg.com.au

An Oshkosh Corporation Company