

460SJ HC3

TELESCOPIC HI-CAPACITY BOOM LIFTS



Performance

Platform Height	14.05 m
Working Height	16.05 m
Horizontal Outreach	12.23 m
Swing 360 Degrees	Continuous
Platform Capacity	
Restricted	340/454 kg
Unrestricted	300 kg
Platform Rotator	180 Degrees Hydraulic
Jib	
Range of Articulation	1.83 m
	130 Degrees (+70, -60)
Weight*	9,250 kg
Max. Ground Bearing Pressure	6.96 kg/cm ²
Drive Speed	6.8 km/h
Gradeability	45%
Tilt Cut Out	5 Degrees
Turning Radius	
Outside	4.8 m
Inside	2.07 m

Standard Specifications

Power Source

Dual Fuel Engine		
Deutz D2.9L4 Tier 4 Final	49 hp	36.4 kW
Fuel Tank Capacity	83.3 L	

Hydraulic Reservoir

• Hydraulic Reservoir	136.27 L
• Auxiliary Power	12V-DC

Tyres

• Standard	12 x 16.5 Foam Filled Non-marking
------------	-----------------------------------

Standard Features

- 180 Degree Hydraulic Platform Rotator
- Platform Console Machine Status Light Panel*
- 5 Degree Tilt Alarm/Indicator Light
- Swing Out Engine Tray
- 12V-DC Auxiliary Power
- Hourmeter
- Improved Multi-Function Controls
- Proportional Controls
- Interactive Display at Ground Controls
- Control ADE® System
- Lifting/Tie Down Lugs
- Horn
- Four-Wheel Hydrostatic Drive
- Inward Self-Closing Swing Gate
- Flashing Amber Beacon
- Operator Tool Tray
- Oscillating Axle
- Motion Alarm
- Glow Plugs (Diesel Engines)
- Load Sensing System
- SkyGuard SkyLine™

*Provides indicator lights at platform control console for system distress, low fuel, 4 degree tilt light, and foot switch status.



3 Capacity Zones - Each rated for 3 occupants + tools/materials

Accessories & Options

- 36 x 72 in. (0.91 x 1.83 m) Platform
- 1/2 in. Air Line to Platform
- Pipe Racks
- White Noise (Squawker) Motion Alarm
- SkySense™
- SkyGlazier
- Light Package¹
- Fire Extinguisher
- Battery Isolator
- Bolt on Fall Arrest
- Mesh to mid rail

Note: Some options may increase lead time, and some option combinations may not be available.

1. Includes platform work lights, head and tail lights, amber beacon.

460SJ HC3

TELESCOPIC HI-CAPACITY BOOM LIFTS



Dimensions

All dimensions are approximate.

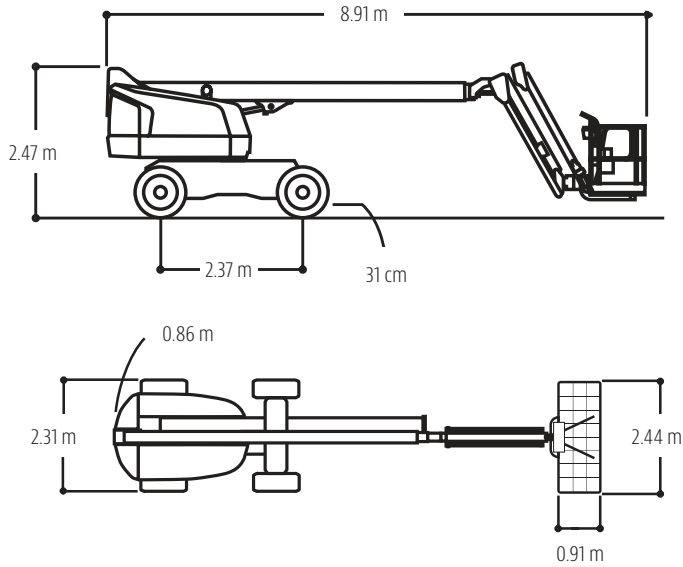

Reach Diagrams

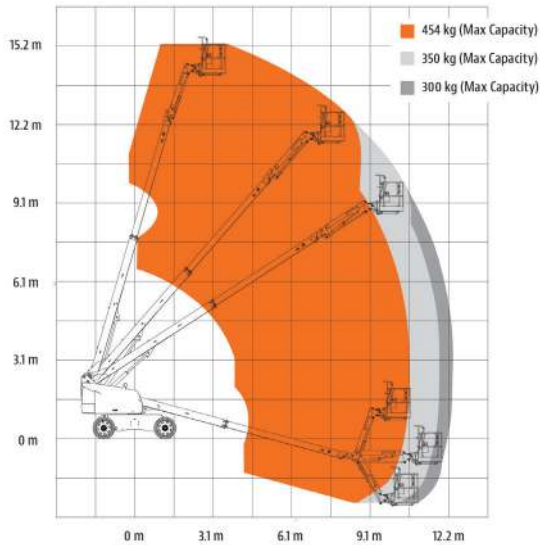

The JLG "1 & 5" Warranty

JLG Industries, Inc. backs its products with its exclusive "1 & 5" Warranty. We provide coverage on all products for one (1) full year and cover all specified major structural components for five (5) years. Due to continuous product improvements, we reserve the right to make specification and/ or equipment changes without prior notification. This machine meets or exceeds AS/NZS 1418.10 2011 as originally manufactured for intended applications.

Part No.: 3131033_AU
R063021



JLG Industries (Australia)

358 Park Road
Regents Park, NSW 2143
Telephone 02 8718 6300
Fax 02 8718 6377
www.jlg.com.au

An Oshkosh Corporation Company