

860SJ

TELESCOPIC BOOM LIFT



Performance

Platform Height		26.21 m
Working Height		28.21 m
Horizontal Outreach		22.86 m
Swing		360 Degrees Continuous
Platform Capacity	Restricted	340 kg
	Unrestricted	230 kg
Platform Size		0.91 x 2.44 m
Platform Rotator		180 Degrees Hydraulic
Jib Length		1.83 m
Jib Range of Articulation		130 Degrees (+70, -60)
Weight		16,900 kg
Drive Speed		5.6 km/h
Gradeability		45%
Turning Radius	Inside	3.80 m
	Outside	6.02 m

Standard Specifications

Power Source

Diesel Engine	Deutz D2011 L04
Fuel Tank Capacity	117.3 L

Hydraulic Reservoir

• Hydraulic Reservoir	151.42 L
• Auxiliary Power	12V-DC

Tyres

- Standard Non-marking Foam-Filled

Standard Features

- 4 Wheel Hydrostatic Drive
- SkyGuard® SkyLine
- 180 Degree Hydraulic Platform Rotator
- Platform Console Machine Status Light Panel*
- SkyPower - AC Generator including AC Outlets to Platform including ELCB
- 4 Degree Tilt Alarm/Indicator Light
- Swing Out Engine Tray
- 12V-DC Auxiliary Power
- Hourmeter
- Proportional Controls
- Control ADE® System
- Lifting/Tie Down Lugs
- Gull Wing Hoods
- Horn
- Oscillating Axle
- Operator Tool Tray
- Inward Self-Closing Swing Gate
- Flashing Amber Beacon
- Load Sensing System
- Fuel Gauge
- Motion Alarm
- Glow Plugs (Diesel Engines)

*Provides indicator lights at platform control console for system distress, low fuel, 4 degree tilt light, and foot switch status.



Accessories & Options

- 0.91 x 1.83 m Platform
- 1/2 in. Air Line to Platform
- White Noise (Squawker) Alarm
- Mesh to Mid Rail
- Fire Extinguisher
- Light Package
- Platform Worklights
- Special Hydraulic Oils
- Spark Arresting Muffler
- Accessory Packages
- SkyGlazier® Package
- PipeRack
- ClearSky
- SkySense

Note: Some options may increase lead time, and some option combinations may not be available.

860SJ

TELESCOPIC BOOM LIFT



Dimensions

All dimensions are approximate.

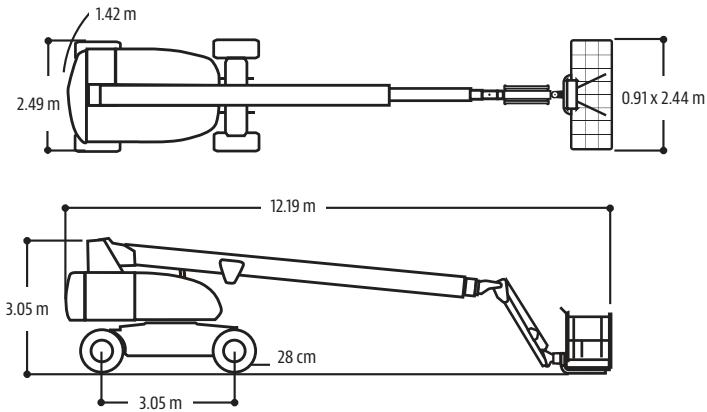

Reach Diagrams

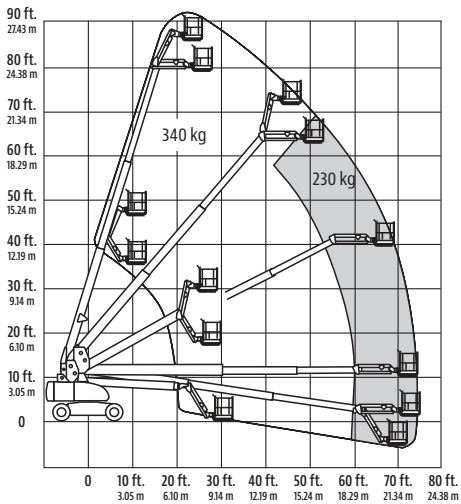

The JLG "1 & 5" Warranty

JLG Industries, Inc. backs its products with its exclusive "1 & 5" Warranty. We provide coverage on all products for one (1) full year and cover all specified major structural components for five (5) years. Due to continuous product improvements, we reserve the right to make specification and/or equipment changes without prior notification. This machine meets or exceeds AS/NZS 1418.10 2011 as originally manufactured for intended applications.

R060520

JLG Industries (Australia)

358 Park Road
Regents Park, NSW 2143
Telephone 02 8718 6300
Fax 02 8718 6377
www.jlg.com.au

An Oshkosh Corporation Company