



## COMPACT 10 DX COMPACT 12 DX

### Outstanding rough terrain driving features

- 4 wheel drive
- Automatic differential lock
- Excellent gradeability (40%)
- Ground clearance of 28 cm

### Robust and easy to maintain

- Outriggers positioned within the machine footprint
- Durable and reliable upper control box
- Optimized accessibility to components
- Built-in diagnosis tool

### Exceptional productivity

- Full proportional controls
- Narrow turning radius
- One switch to deploy and retract 4 outriggers





# COMPACT 10 DX / COMPACT 12 DX

## ROUGH TERRAIN SCISSOR LIFTS

### TECHNICAL DATA

### Compact 10 DX Compact 12 DX

|                           |                   |                   |
|---------------------------|-------------------|-------------------|
| Working height            | 10.28 m           | 12.06 m           |
| Platform height           | 8.28 m            | 10.06 m           |
| Lift capacity             | 565 kg            | 450 kg            |
| <b>A</b> Length           | 3.17 m            | 3.17 m            |
| <b>B</b> Width            | 1.78 m            | 1.78 m            |
| <b>C</b> Height - stowed  | 2.44 m            | 2.56 m            |
| Storage height            | 1.59 m            | 1.7 m             |
| <b>F</b> Platform length  | 2.45 m            | 2.45 m            |
| Extended platform length  | 3.7 m             | 3.7 m             |
| Platform extension length | 1.2 m             | 1.2 m             |
| <b>G</b> Platform width   | 1.45 m            | 1.45 m            |
| <b>D</b> Wheelbase        | 1.84 m            | 1.84 m            |
| <b>E</b> Ground clearance | 28 cm             | 28 cm             |
| Number of extensions      | 1                 | 1                 |
| Drive speed               | 0,8 - 5,5 km/h    | 0.8 - 5.5 km/h    |
| Turning radius - outside  | 3.5 m             | 3.5 m             |
| Lift / lower speed        | 35 s / 46 s       | 35 s / 51 s       |
| Engine                    | 18.5 kW - 24.8 hp | 18.5 kW - 24.8 hp |
| Gradeability              | 40 %              | 40 %              |
| Tires - foam-filled       | 26x12-16.5        | 26x12-16.5        |
| Hydraulic system capacity | 75 l              | 75 l              |
| Weight                    | 3 520 kg          | 4 110 kg          |

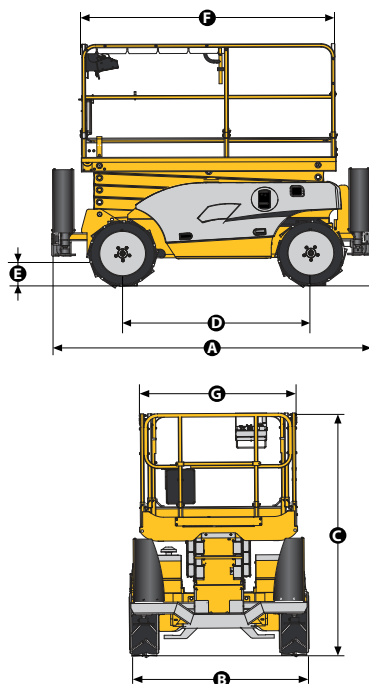
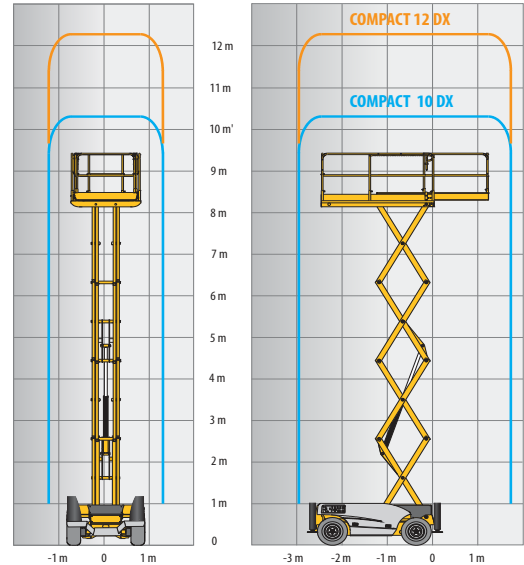

### STANDARD EQUIPMENT

- Kubota engine
- 4 wheel drive, 2 wheel steer
- 3° Tilt alarm
- 1,2m platform extension
- 12V - 74 Ah Batteries
- Removable operator's control box
- Brake release
- Hourmeter
- Towing hooks
- Hydraulic brakes
- Manual platform lowering valve
- Foam filled all terrain tyres
- Automatic levelling outriggers
- Side shields
- Horn
- Lanyard attachment points
- Swing-door gate

### OPTIONS AND ACCESSORIES

- Non marking tyres
- Rotating beacon
- 240 V power to the platform
- Travel alarm
- Motion alarm for movements and translation
- Working light
- Biodegradable oil
- Cold Weather Package
- Foldable guard-rails
- Hydraulic generator 3.5 kW

Non contractual document - We reserve the right to modify the technical characteristics of this document without notice - 10/2016

