

## HA26 RTJ PRO



### PERFORMANCE & PRODUCTIVITY

- > Very good working envelope
- > Vertical arm rise - Basket remains parallel to wall
- > Outstanding RT capabilities
- > Basket load capacity 250 kg
- > Dual load 250-350 kg (option)

### SAFETY AND COMFORT

- > Quick, proportional and simultaneous movements
- > Haulotte Activ' Lighting System safe load
- > Haulotte Activ' Shield Bar 2.0

### MAXIMIZED TOTAL COST OF OWNERSHIP

- > Haulotte Activ'Screen (on board diagnostic)
- > Haulotte Stop Emission System automatically turns the engine off & on
- > Easy access to all components
- > Large modular basket, quick and easy to repair

# HA26 RTJ PRO

ROUGH TERRAIN  
ARTICULATED BOOMS

## TECHNICAL DATA

### HA26 RTJ PRO

Working height	26.4 m
Platform height	24.4 m
Horizontal outreach	17.5 m
Up and over clearance	9.3 m
Lift capacity	250 kg (option 350kg)
<b>F</b> x <b>G</b> Platform size	2.44 x 0.91 m
<b>A</b> Length - stowed	11.8 m
<b>B</b> Width	2.48 m
<b>C</b> Height - stowed	2.97 m
<b>H</b> Transport length	9.4 m
Transport height	2.98 m
Vertical jib rotation	133° [-65°/+68°]
Platform rotation	180 °
Turntable rotation	360° continuous
Tailswing	0.76 m
<b>D</b> Wheelbase	2.8 m
Ground clearance	48 cm
Tilt	4 °
Drive speed	5 km/h
Gradeability	45 %
Turning radius - outside	4.35 m
Tyres - solid rough terrain	1025x365 mm
Power source	Kubota, 36.5kW (49.6hp), Stage 3A
Weight	15 500 kg

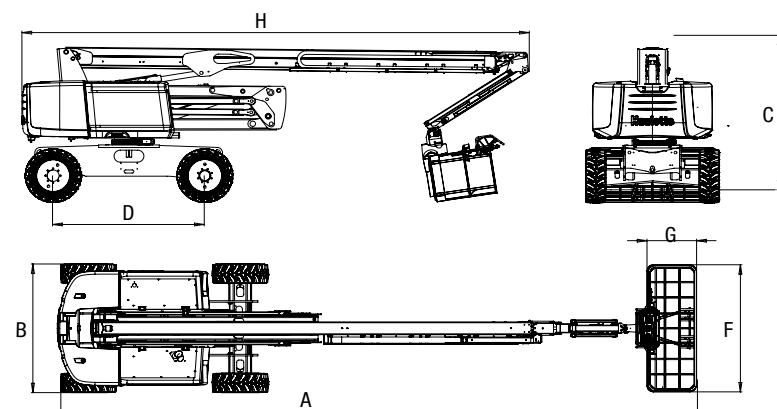

## STANDARD EQUIPMENT

- > Haulotte Activ' Screen: embedded diagnostic system on lower control box, with color screen
- > Haulotte Activ' Shield Bar 2.0
- > Haulotte Activ' Lighting System, Safe load
- > Haulotte Stop Emission System : automatic engine stop system
- > Universal telematics plug
- > 4 wheel drive, 4 wheel steer
- > Front oscillating axle
- > 4 simultaneous movements
- > Automatic differential wheel lock
- > Upper control box cover
- > Tool tray
- > 250 kg (2 persons) load capacity unrestricted working envelop
- > Large modular Haulotte basket 2.44 m x 0.91m
- > Drop bar entry gate
- > AC power to platform (110 / 230V)
- > Swing out engine tray
- > Sound and light alarm for tilt and load
- > Rotating beacon
- > Travel alarm
- > Electric pump system and emergency descent
- > 12V battery / electrical control system
- > Engine pre-heater with light indicator
- > Low fuel level indicator (upper control box), fuel gauge (lower control box).

## OPTIONS AND ACCESSORIES

- > Non marking tyres
- > Dual load capacity 250 / 350 kg (restricted)
- > Power to platform (female plug in the basket)
- > Air-line to platform
- > Lateral swing door entry gate
- > Hydraulic generator 3.5 kW or 6.5 kW
- > Biodegradable hydraulic oil
- > Hydraulic oil cooler
- > Cold weather kit -20° / Arctic weather kit -25°C
- > Pipe cradle pack
- > Glazier pack
- > Working light
- > Battery circuit breaker

