



## OPTIMUM 8

### Best driving and lifting experience

- AC powered
- High precision driving
- Proportional and quick movements
- Best turning radius

### Utmost versatility

- Ability to go through standard doorways
- Mobile potholes protection
- Indoor - Outdoor rated

### Minimal maintenance and downtime

- Maintenance free AC motors
- Easy access 2 swing out trays
- Haulotte ACTIV'Screen (onboard diagnostic)
- Smart transportability

### Longer life time

- Extreme robustness
- Optimized total cost of ownership





# OPTIMUM 8

## ELECTRIC SCISSOR LIFTS

### TECHNICAL DATA

#### Optimum 8

|                                      |                     |
|--------------------------------------|---------------------|
| Working height                       | 7.77 m              |
| Platform height                      | 5.77 m              |
| Driveable at full height up to       | 5.77 m              |
| Lift capacity - inside               | 230 kg              |
| Lift capacity - outside              | 230 kg              |
| <b>A</b> Platform length - outside   | 1.72 m              |
| <b>B</b> Platform length - extended  | 2.59 m              |
| Length - extension                   | 0.86 m              |
| <b>C</b> Platform width - outside    | 0.74 m              |
| <b>D</b> Height - stowed             | 1.98 m              |
| <b>E</b> Overall width               | 0.79 m              |
| <b>F</b> Length                      | 1.9 m               |
| <b>G</b> Wheelbase                   | 1.38 m              |
| <b>H</b> Ground clearance - Center   | 8.7 cm              |
| Ground clearance - Deployed potholes | 2 cm                |
| Drive speed                          | 0.5 - 4.5 km/h      |
| Gradeability                         | 25 %                |
| Tilt                                 | 1.5° - 3°           |
| Lift / lower speed                   | 20 s / 29 s         |
| Turning radius - outside             | 1.5 m               |
| Non-marking tires                    | 12.5 x 4.13         |
| Batteries                            | 24 V - 225 Ah (C20) |
| Hydraulic system capacity            | 7 l                 |
| Weight                               | 1 520 kg            |

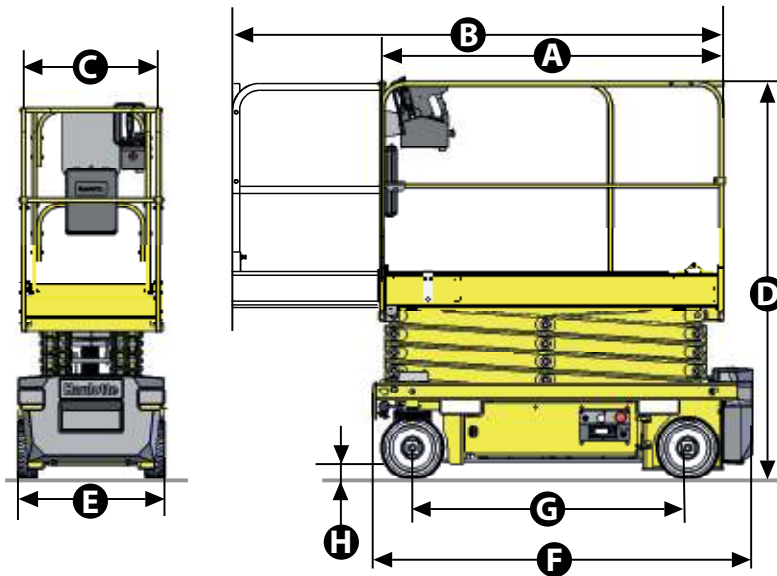

### Optimum 8

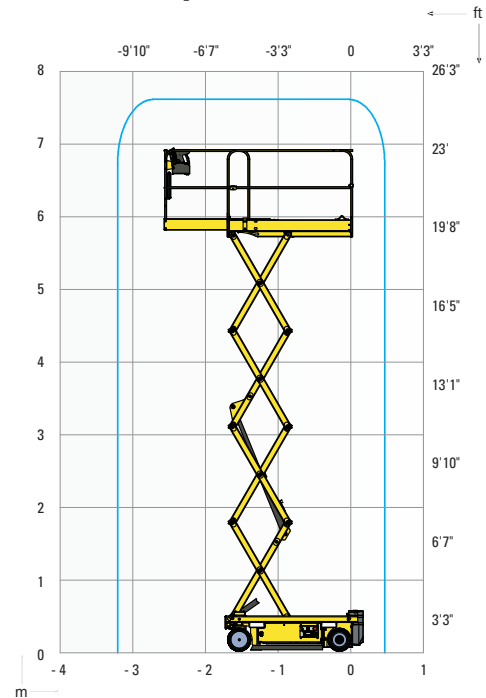

### STANDARD EQUIPMENT

- 24 V electric drive Brushless AC motors
- Battery charge indicator
- Battery level indicator on upper and lower control boxes
- Haulotte Activ'Screen (battery charge, Hourmeter, service alert & failures icons in code or in full text...)
- 2 swing out trays
- Lateral fork lifting pockets
- Electric or manual break release system
- lifting and stowage points
- Non marking tires
- 

### OPTIONS AND ACCESSORIES

- Maintenance free gel batteries
- Pipe cradle
- Swing door entry gate
- Flashing light
- Dual flashing lights
- Working light
- AC power to platform
- Hydraulic oil for cold countries