

STAR 8 / 10

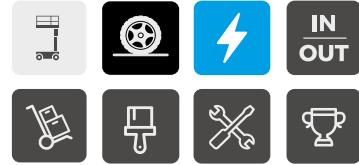

OPTIMAL AGILITY IN CONFINED WORKING AREAS

- > Progressive electric drive AC motors
- > Zero tail swing & tight turning radius
- > 3m outreach vertical jib
- > Minimal maintenance & downtime
- > Maintenance free brushless AC motors
- > Haulotte Activ'Screen (onboard diagnostic)

CENTRALIZED BATTERY FILLING

- > Longer life time
- > New unbreakable hoods in composite material
- > Durability multiplied by 3 on pins, bushes, non-painted parts and fastening hardware
- > Smart transportability
- > Versatile and effective transport solutions with forklift tine pockets
- > 25% gradeability to easily climb truck ramps



VERTICAL MASTS

TECHNICAL DATA

STAR 8 STAR 10

Working height	8.7 m	10 m
Platform height	6.7 m	8 m
Horizontal outreach	3 m	3 m
Lift capacity - inside	200 kg (2 pers.)	200 kg (2 pers.)
Lift capacity - outside	200 kg (2 pers.)	200 kg (1 pers.)
Platform size	0.78 x 0,98 m	0.78 x 0,98 m
D Length	2.7 m	2.7 m
B Width	1 m	1 m
Tailswing	0 cm	0 cm
C Wheelbase	1.2 m	1.2 m
A Height - stowed	1.99 m	1.99 m
E Ground clearance	10 cm	10 cm
Driveable at full height up to	6.7 m	8 m
Drive speed proportional	0.6 - 5 km/h	0.6 - 5 km/h
Turning radius - outside	1.88 m	1.88 m
Turntable rotation	345°	345°
Vertical jib rotation	130° (+70°/-60°)	130° (+70°/-60°)
Tyres - non marking	16x5x10.5	16x5x10.5
Tilt alarm	3 °	3 °
Gradeability	25 %	25 %
Hydraulic system capacity	7 l	7 l
Power source	24 V - 250 Ah	24 V - 250 Ah
Weight	2 585 kg	2 677 kg

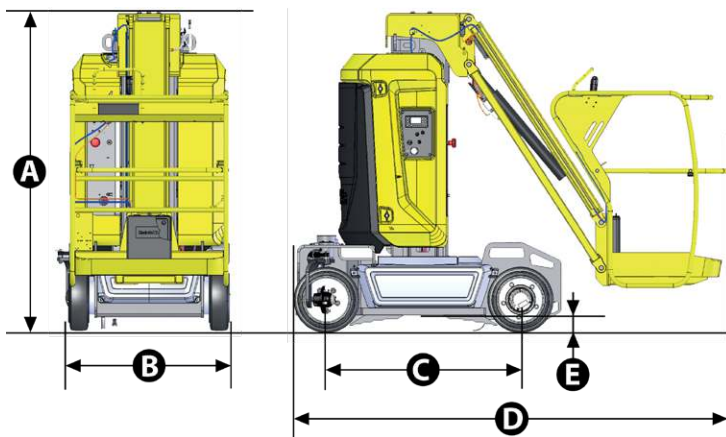

STANDARD EQUIPMENT

- > 24 V electric drive brushless AC motors
- > 24 V - 250 Ah traction batteries
- > 35 A battery charger
- > Battery charge indicator
- > On-board diagnostic tool Haulotte Activ'Screen
- > Centralised battery filling
- > Forklift tine pockets
- > Towing hooks and lifting eyes
- > Passive potholes
- > 2 front driving wheels
- > 2 rear steering wheels
- > Non-marking tires
- > Brake release
- > Hourmeter
- > Horn
- > Emergency stop buttons at cage and ground level
- > Load controller in the platform
- > Emergency hand pump
- > 2 control stations at cage and ground level
- > 2 rings in the platform for safety harnesses
- > Travel alarm

OPTIONS AND ACCESSORIES

- > Haulotte Activ'Shield Bar
- > Power line in platform
- > Air line in platform
- > Swing door entry gate
- > Biodegradable oil
- > Maintenance-free batteries
- > Telematics ready
- > Hydraulic oil for cold countries
- > Flashing light
- > Working light

